



H-3551T

GAS PURGE BUBBLER



a xylem brand

CONTENTS & WARRANTY

This user manual is a guide for the H-3551T. For more information, updated manuals, brochures, technical notes, and supporting software on the H-3551T, please refer to waterlog.com/3551 or contact your sales representative.

For additional assistance, please contact us at +1.435.753.2212 or sales@waterlog.com

WaterLOG® Warranty	1
Chapter 1: Introduction	2
Bubbler Features.....	3
Chapter 2: Getting Started	4
What's in the Box.....	5
Chapter 3: Installation	6
Product Description.....	7
Orifice & Sensor Connections.....	7
Recommended Field Installation Procedures.....	8
Chapter 4: Setup & Operation	10
Maintenance Pressure Pump Procedures.....	11
Purge Pump Failure.....	11
Operation with H-350XL.....	11
Stand-alone Operation.....	13
Manual Purge.....	14
Chapter 5: Maintenance & Troubleshooting	15
Bubble Test.....	17
Chapter 6: SDI-12 Command & Response Protocol ...	18
Command Summary.....	19
Measure Command.....	20
Concurrent Measure Command.....	22
Send Data Command.....	22
Send Acknowledgement Command.....	23
Initiate Verify Command.....	23
Send Identification Command.....	24
Change Sensor Address Command.....	25
Extended Commands.....	25-28
Chapter 7: Appendix	29



a xylem brand

Contents & Warranty

"WATERLOG™ PRODUCTS MANUFACTURED BY YELLOW SPRINGS INSTRUMENTS CO., INC. are warranted by Yellow Springs Instruments Co., Inc. ("YSI") to be free from defects in materials and workmanship under normal use and service for twelve (12) months from date of shipment unless otherwise specified in the corresponding YSI pricelist or product manual.

WaterLOG™ products not manufactured, but that are re-sold by YSI, are warranted only to the limits extended by the original manufacturer. Batteries, desiccant, and other consumables have no warranty. YSI's obligation under this warranty is limited to repairing or replacing (YSI's option) defective products, which shall be the sole and exclusive remedy under this warranty.

The customer shall assume all costs of removing, reinstalling, and shipping defective products to YSI. YSI will return such products by surface carrier prepaid within the continental United States of America. To all other locations, YSI will return such products best way CIP (Port of Entry) INCOTERM® 2010, prepaid. This warranty shall not apply to any products which have been subjected to modification, misuse, neglect, improper service, accidents of nature, or shipping damage. This warranty is in lieu of all other warranties, expressed or implied. The warranty for installation services performed by YSI such as programming to customer specifications, electrical connections to products manufactured by YSI, and product specific training, is part of YSI's product warranty. YSI EXPRESSLY DISCLAIMS AND EXCLUDES ANY IMPLIED WARRANTIES OF MERCHANTABILITY OR FITNESS FOR A PARTICULAR PURPOSE. YSI is not liable for any special, indirect, incidental, and/or consequential damages."

A complete TERMS AND CONDITIONS OF SALE can be viewed at:
<http://www.yxi.com/terms-and-conditions.php>



01 / INTRODUCTION

Introduction

The WaterLOG® H-3551T is a self-contained “smart” gas purge system which produces a precision, constant mass flow of gas. Together with a pressure measurement device, it is used to measure fluid levels in applications such as surface water (streams and lakes, etc.), ground water and tanks.

A sophisticated system of sensors and valves regulate the bubble rate and purge pressure. A battery operated compressor and an internal microprocessor controller determines how much pressure is needed in the tank based on the current head pressure, to produce a constant bubble rate. Hence, the term “smart”. The micro controller also compensates for the effects of gas density change with temperature to maintain a constant flow through the restriction. This portion of the H-3551T replaces the sight feed flow controller and pressure regulator (Conflow system) used in previous systems.

The bubbler also provides a purge feature which temporarily pumps up the tank to a high pressure and opens a valve to apply high pressure to the orifice line. This feature is designed to remove any sediment that may have collected in or around the outlet of the orifice line.

The H-3551T is used primarily with the WaterLOG® H-350XL data logger, which performs several different functions in the system. First, it is the precision pressure measurement source for measuring the fluid level. This function replaces the manometer in previous systems. Second, it is the terminal through which the H-3551T is configured. Third, it can be the data recorder for the system, thus removing the need for an external data recorder.

Key Features:

- Provides a continuous gas flow
- Battery operated
- Microprocessor controlled
- One-piece manifold eliminates many potential sources of leaks
- Pressure gauge provides a visual indication of the tank pressure
- Hydrophobic intake membrane protects compressor
- All components are easily accessible for inspection and maintenance
- Compressor does not have a “diaphragm”
- Provides an internal pressure relief valve
- Compressor is designed and rated for cold temperature operation



02 / GETTING STARTED

Getting Started

Before installation, setup and operation of the H-3551T in the field, read through this section for a general overview of what you have and how to use it.

What's in the Box

When unpacking your H-3551T, make sure all the components ordered are received and undamaged from shipping. Some movement may have occurred during shipping. It is recommended that you visually inspect the inside of the enclosure to verify all electrical connections are secure. The **basic package includes:**



H-3551T Bubblers



CABLE ASSY,SDI,H-3551



CABLE ASSY, RS-485, H-3551 TO XL SERIES



H-355-INS-INSTALL KIT: (2) 1/8" NPT to 1/8" Tube Fittings,
(1) 1/8" NPT to 3/8" Tube Fittings, 6 ft. 1/8" Copper Tubing



Mounting Hardware

Before installing the H-3551T you may wish to test the system in the shop or lab. This will familiarize you with the instrument in an environment where it is easy to work and you are near a telephone if questions should arise.

If you are unable to get the H-3551T up and running, refer to Chapter 3 (Installation) and Chapter 4 (Trouble Shooting). If you have further questions, feel free to call one of our support personnel at +1.435.753.2212 option 2, for assistance.

03 / INSTALLATION

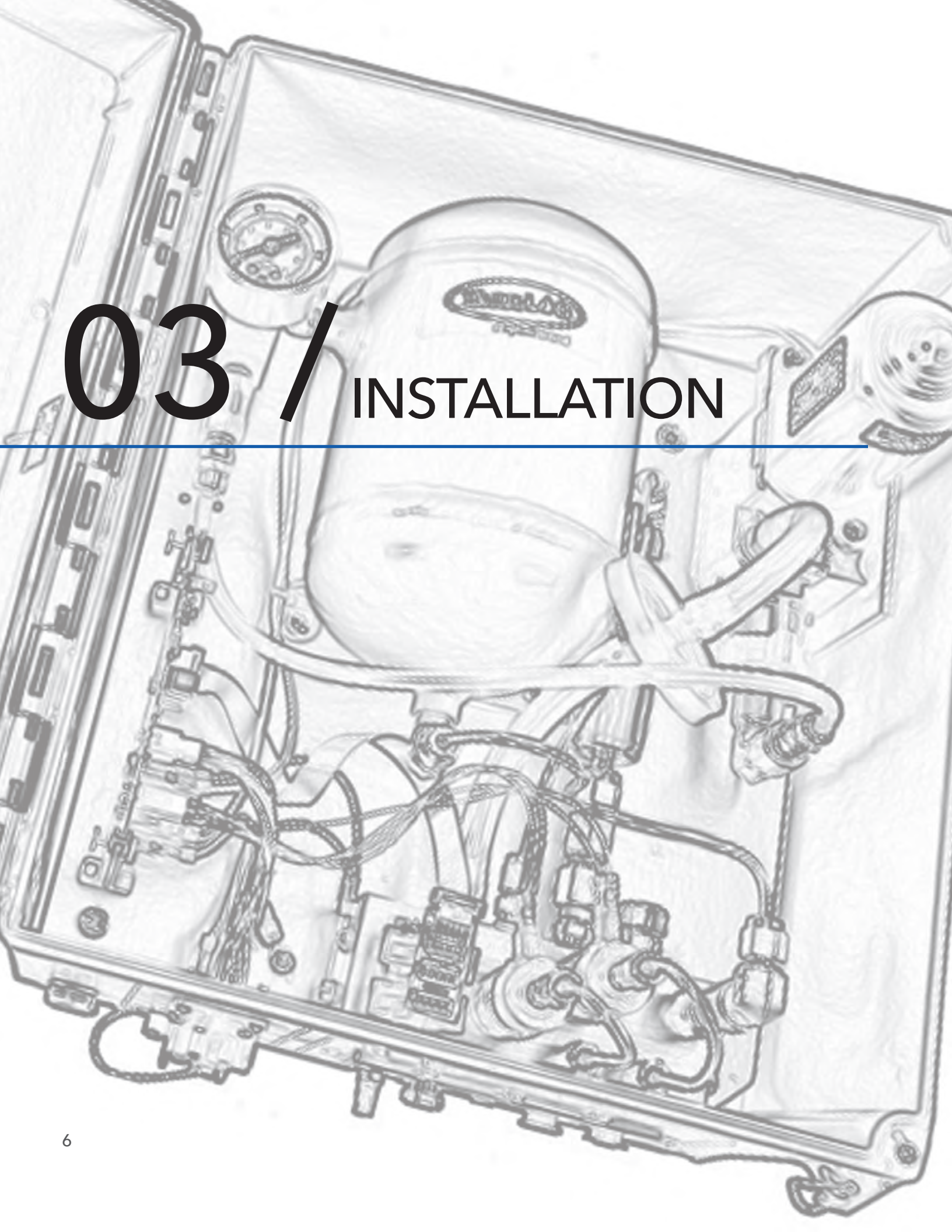

Installation

Installation instructions for the H-3551T may vary depending on your specific application and field conditions. It is important to familiarize yourself with the connections before installing a product at the site. Below are standard connections found on the H-3551T.

Power & Communications Main Interface Connection

Enclosure Breather

Compressor Power (Connect First)

Atmospheric PSI Vent for Sensors

Compressor Air Intake Desiccator Connection

Constant Bubble Out Orifice Line Connection 1/8 inch FNPT

H-350XL Sensor Setup Port & Cable Connection



Orifice and Sensor Connections

In its simplest form, a gas purge pressure measurement system consists of a gas source, a pressure measurement device and an orifice tube all connected together in a "T" arrangement. Because the H-3551T has the capability of purging the orifice line, a more complex connection is required. Do not use a simple "T" connection to connect the bubbler and pressure sensor to the orifice line, instead, use the two dedicated ports of the H-3551T. The H-3551T includes an internal valve which isolates the pressure sensor output from the orifice line during a purge sequence. This helps prevent a plugged orifice condition from damaging the pressure sensor.

If you are using a pressure sensor other than the H-350XL, you may need to take extra precautions to further protect your pressure sensor (see chapter 4).

INSTALLATION

Recommended Field Installation Procedures

1. The H-3551T must be wall mounted in the vertical position, with the manifold down. Mounting feet are provided. A vertical mount helps ensure moisture will not accumulate in the internal pressure tank.
2. Connect the pressure line between the H-3551T and your pressure measurement device. This can be done using the H-3551T Install kit. This kit is designed for use with the H-350XL. If your measurement device has different connections, you will need to provide the appropriate fittings. You will need a 1/8" NPT male tubing fitting for the sensor output. It is recommended that you use the 1/8" copper tubing supplied in the install kit. The proper ferrules must be used to insure there are no leaks.
3. The H-3551T requires two separate power sources. First is the compressor 12V which powers the compressor and control valves. This supply is typically made with heavy gauge wire to the gauge station 12V battery. Second is the 12V which powers the control module. This source is supplied from the pressure measurement sensor through the interface cable (provided), and into the control connector. It is best to connect the compressor power first, then the control power second. If a pumping sequence fails, the controller suspends pumping for a while to allow the battery to recharge. By connecting the pump power first, the controller will not prematurely detect a dead battery and suspend pumping.
4. Generally, an external desiccator is required to dry the intake air. The desiccator prevents accumulation of moisture in the tank, restriction and orifice line. Connect the output of the desiccator to the port marked "intake". Desiccators which employ "indicating" silica gel have the advantage of visually showing the status of the desiccant. As the gel becomes saturated with moisture, the gel turns blue. See Appendix-B for further information and the specification for a recommended desiccator.

Table 3-1: H-3551T Control Connector

Pin No.	Description	Wire Color
1	RS485DAT+	Black
2	RS-485DAT-	Brown
3	GND	Red
4	GND	Orange
5	+12V	Yellow
6	+12V	Green
7	+12V	
8	SD-12 Data	
9	Gnd	

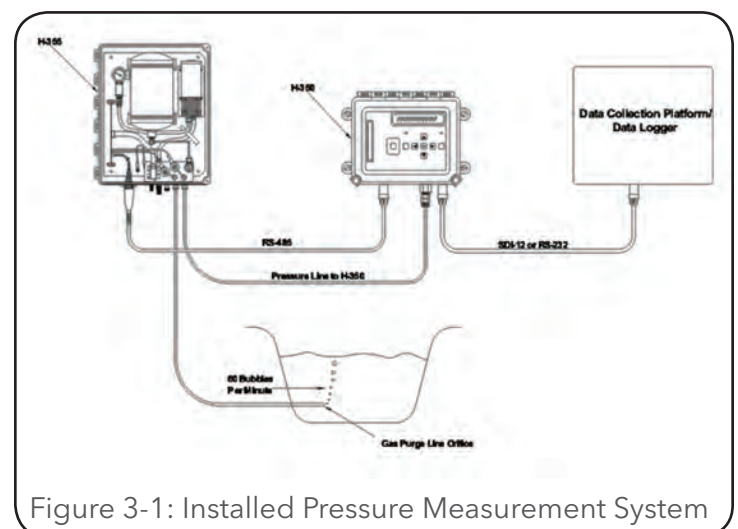

Figure 3-1: Installed Pressure Measurement System

Installation

Please note the following:

1. The install kit provided connects the "Sensor" output port of the bubbler directly to the "Pressure Input" of the H-350XL without any additional parts.
2. The RS-485 serial cable provided is equipped with plugs on both ends for direct connection between the "control" input of the H-3551T and the "Auxiliary output" of the H-350XL

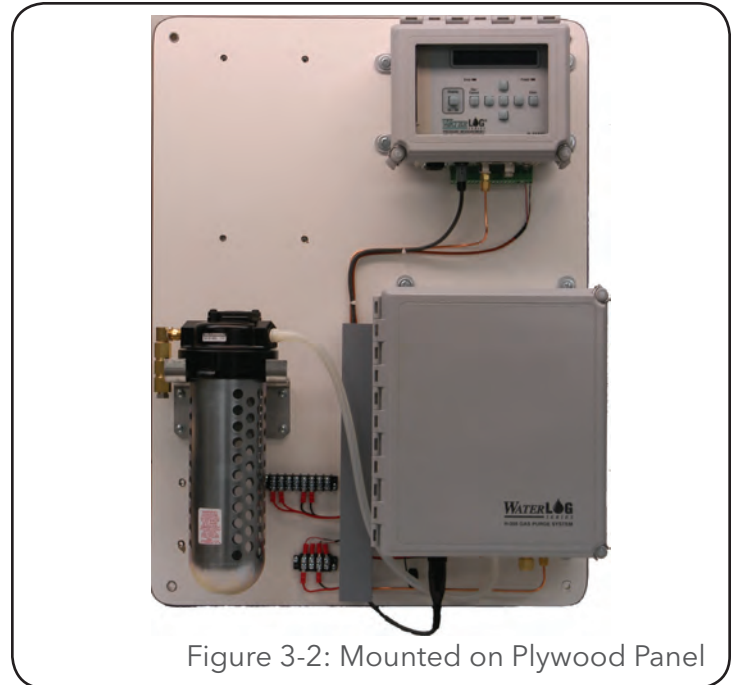
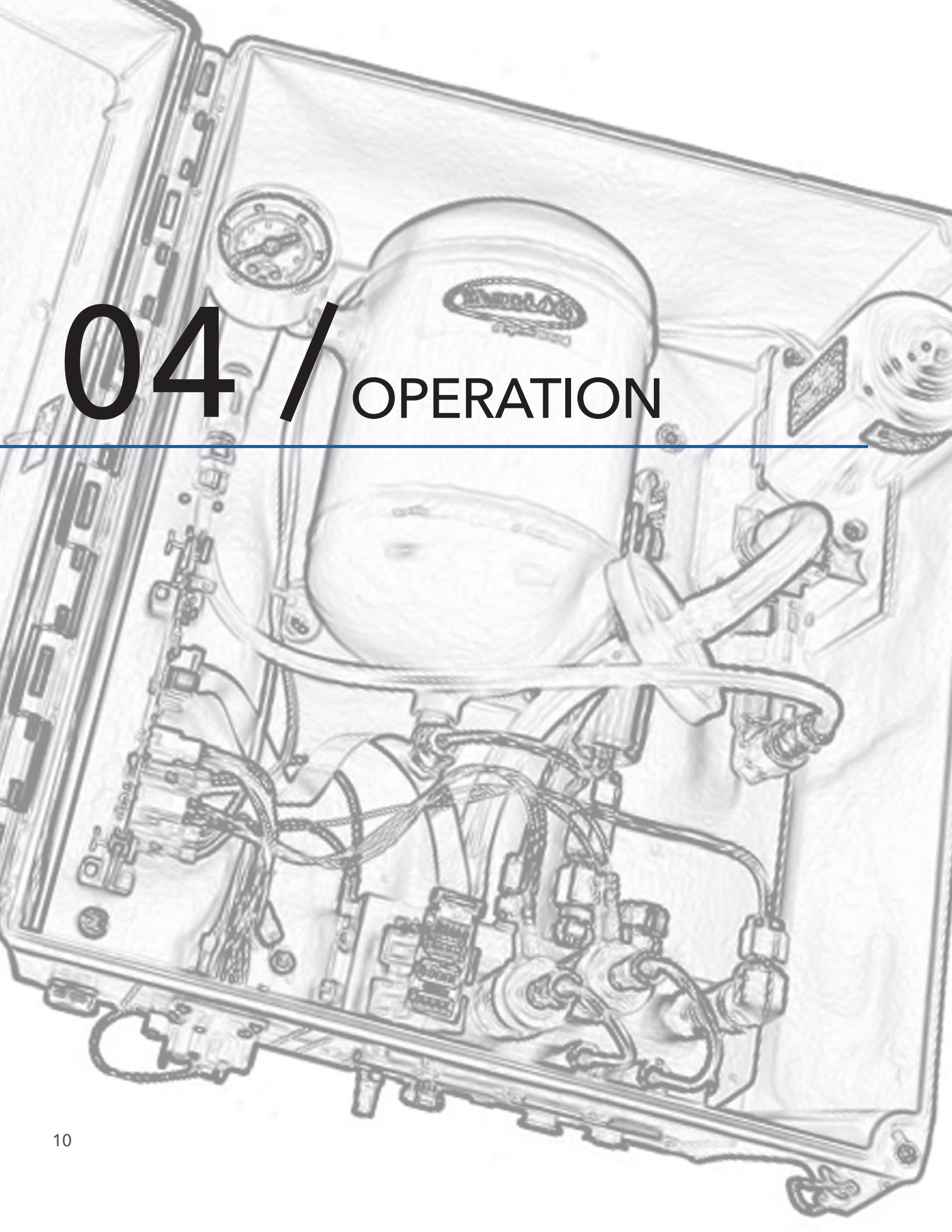

Figure 3-2: Mounted on Plywood Panel



04 / OPERATION

Operation

During normal operation, if the tank pressure becomes too low the micro controller makes several tests before turning the compressor on:

1. If the compressor power input (terminal strip) is below 10.0 volts, the compressor will not turn on. This is to prevent further discharge of an already stressed battery.
2. The compressor will not be turned on if a purge sequence within the previous elapsed 1-hour failed. This allows the battery charger to charge the battery without the compressor draining the battery as fast as it is charged. Once the compressor is turned on, the battery voltage is no longer monitored by the microcontroller.

Maintenance Pressure Pump Failure

If the compressor runs longer than 60 seconds while pumping the tank to the pressure needed for the desired bubble rate, the micro controller turns off the compressor and disables further pumping for 30-seconds.

Purge Pump Failure

When a purge sequence is initiated, the compressor is activated to pump the tank to the specified purge pressure. If the compressor runs longer than 300 seconds while pumping the tank to the proper pressure, the micro controller turns off the compressor and disables all further pumping for 1-hour.

While servicing the system, these battery protection features can be inadvertently activated if the 12V pump power (via the terminal strip) is disconnected or fails while the compressor is running. You can recover from these lockout conditions by momentarily disconnecting the RS-485 control connector to reset the micro controller.

Operation with the H-350XL

The following is a description of the H-350XL submenus used for configuring the bubbler.

<Gas Purge Setup >	Auto Purge Enbl[OFF]
	Bubble Rate[XXX]/min
	Purge Thresh[XXX]PSI
	Purge Presur[XXX]PSI
	Purge Time: [XXX]sec
	Manual Purge: ENT=Y
	Timed Prg: [XX] days
	Tank PSI = XX.X
	Diff PSI = XX.XX
	LastPrg=MM/DD HH:MM



OPERATION

The H-350XL can sense when the orifice line is restricted or plugged. The system can be configured to do an automatic purge of the orifice line when it becomes necessary. This menu item turns the auto purge on or off.

<Gas Purge Setup >	Auto Purge Enbl[OFF]
--------------------	----------------------

This setting specifies the bubble rate that should flow from the end of the orifice tube. The programmable range is 30 to 120 bubbles per minute.

<Gas Purge Setup >	Bubble Rate[XXX]/min
--------------------	----------------------

This setting sets the purge threshold. If the orifice line pressure reaches the purge threshold, the H-350XL can initiate an auto purge. The range of "Purge Thresh" is 10 to 65 psi.

<Gas Purge Setup >	Purge Thresh[XXX]PSI
--------------------	----------------------

This setting is the pressure that the H-3551T uses to purge the orifice line. The range is 15 to 80 psi. Set this value to a pressure which would reasonably purge sediment and debris from the orifice. Keep in mind that the higher pressures require more energy from the battery.

<Gas Purge Setup >	Purge Presur[XXX]PSI
--------------------	----------------------

This setting is the duration of a purge in seconds. The range is 30 to 240 seconds. Allow enough time for the purge to dissipate and the bubble rate to fall near zero.

<Gas Purge Setup >	Purge Time: [XXX]sec
--------------------	----------------------

Pressing <Enter> on this item will initiate a purge sequence using the current purge settings.

<Gas Purge Setup >	Manual Purge: ENT=Y
--------------------	---------------------

This option is used to force a purge every XX days. The limits are 00 to 99 days. If the option is set to 00 then this option is in affect disabled. A value of 01 will cause a purge every day. The purge will happen after the first scan past noon.

<Gas Purge Setup >	Timed Prg: [XX] days
--------------------	----------------------

This value is the current pressure of the H-3551T's internal air tank in psi. This value is informative only and cannot be edited. The tank pressure should be approximately 3-5 PSI greater than the orifice pressure.

<Gas Purge Setup >	Tank PSI = XX.X
--------------------	-----------------

Operation

This value is the difference between the tank pressure and the pressure on the orifice line in psi. Like tank psi, this value cannot be edited. This value is directly proportional to the bubble rate and should be approximately 3-5 PSI.

<Gas Purge Setup >	Diff PSI = XX.XX
--------------------	------------------

This display shows the month, day any hour when the last purge sequence was made.

<Gas Purge Setup >	Last Prg=MM/DD HH:MM
--------------------	----------------------

If the auto-purge feature of the H-350XL is enabled, the H-350XL is responsible for initiating purges. Whenever the H-350XL makes a measurement, it compares the pressure data with the "Purge Threshold" value. If the pressure is greater than the Purge Threshold, the H-350XL commands the bubbler to initiate a purge sequence. During the purge, the H-350XL energizes its internal auto-zero valve to isolate the H-350XL's precision sensor from the purge pressure. At the completion of the purge, the H-350XL keeps its auto-zero valve energized for an additional 2.0 seconds. This is done to prevent damage to the H-350XL's precision sensor in case the orifice is plugged and the orifice line momentarily holds the full purge pressure. A pressure relief valve in the bubbler vents the over pressure to atmosphere during the 2 second delay.

After completion of a purge sequence, the H-350XL makes another pressure measurement. If the pressure is still greater than the Purge Threshold value, the H-350XL knows the purge failed. It then activates a timer which disables further purges for the next 24 hours. This is done to prevent a plugged orifice from causing continuous purges which would quickly drain the battery.

Stand-Alone Operation

The H-3551T gas purge system can be used "stand-alone" with pressure measurement devices other than the H-350XL. You do lose some flexibility in that you cannot edit the bubbler settings in the field and the purge feature cannot be coordinated with a pressure measurement such that pressure measurements are not made during a purge.

When operating stand-alone, the factory preset values are:

- Bubble Rate: 60 Bub/min
- Pressure to Purge With: 40 PSI
- Pressure to Initiate a Purge: 20 PSI
- Purge Time: 45 sec

These settings can also be monitored or edited via the SDI-12 port built into the H-3551T. The H-3551T functions as a SDI-12 "sensor". When connected to a SDI-12 host such as a data logger or H-4191 RS-232 side-kick interface you can issue extended SDI-12 commands to read or write these settings. If the data logger issues an "aM!" command, the H-3551T initiates a purge sequence. See Chapter 5 for further details.

If needed, these settings can be configured at the factory. The factory must be notified of desired settings prior to shipment.

OPERATION

WARNING: THERE IS A DISTINCT POSSIBILITY OF DESTROYING YOUR PRESSURE SENSOR. THIS CAN BE AVOIDED BY INSTALLING AN ISOLATION VALVE BETWEEN THE H-3551T AND YOUR SENSOR.

If a purge does not clear a plugged orifice line, the purge pressure will be applied to the sensor output of the H-3551T. The H-350XL has an internal valve which protects its precision pressure transducer from a failed purge. When operating the H-3551T with a sensor other than the H-350XL, the purge pressure could be applied to your sensor before the H-3551T's internal pressure relief valve can pop. It is your responsibility to verify that your sensor can handle the purge pressure, or install an isolation valve between the H-3551T and your sensor. The valve must be closed prior to a purge and remain closed until the purge is completed, or until the tank pressure falls below your sensor's maximum pressure rating.

Manual Purge

The H-3551T has an internal button which allows a manual purge to be initiated. This feature allows you to clear a plugged orifice or verify the orifice is clear. The Purge button is located inside the H-3551T enclosure, on the top corner of the control module. Pressing this for one to two seconds initiates a purge sequence. The compressor will be turned on and the tank pressure raised to the "Purge Pressure". During this time, the bubble rate will rise proportionally with the pressure. Next, the compressor is turned off and the purge valve is actuated to dump the tank pressure directly to the orifice line. While the purge valve is actuated the pressure sensor output is blocked by a valve to prevent the purge pressure from damaging the pressure measurement system. During the purge, the orifice should produce vigorous bubbling with the bubble rate falling eventually to zero. After a delay equal to the "Purge Delay", the purge valve is closed and the compressor is again turned on to restore the bubble rate to its normal value.

NOTE: When the button is pressed, if the tank pressure is already higher than the "Purge Pressure" the purge sequence will not be initiated.



05 / MAINTENANCE & TROUBLE SHOOTING

MAINTENANCE & TROUBLE SHOOTING

Maintenance

Sustained operation of the H-3551T is almost maintenance-free. Because the compressor only runs for a few seconds every hour, it will last for many years. The H-3551T includes safety provisions that will not allow the compressor to run continuously for long periods of time. This protects the pump and other components in case of a plugged orifice or other malfunction.

Periodically check your gauge station battery to ensure it is in good condition for pumping together with any other equipment that you have installed in the gauge station.

From time to time check the inlet line filter (located between the manifold and the suction side of the pump) for any blockage or restriction. If blockage or restriction is present, the filter must be replaced.

All fittings must be secure. At 60 bubbles/minute, even a tiny leak will allow the entire gas flow to escape.

Trouble Shooting

It is unlikely that this manual will ever contain trouble shooting tips to cover every problem that will be encountered. Feedback from customers is very valuable and greatly aids in the quest for constant product enhancement. Please feel free to call the factory for technical assistance and also with solutions you have found to past problems.

The following list of problems and possible solutions.

H-350 reports "H-355 NOT RESPONDING"!

- Verify the power connections to the H-3551T. Reinitialize the internal controller by momentarily unplugging the RS-485 control cable connector.
- Check all connections including Power, Gnd and the RS-485 communication connector. +12V power must be supplied via both the compressor power terminals and the RS-485 connector (from the data logger)

Intermittent Operation

- Check your power and ground connections. Moisture over time can oxidize and corrode the battery terminals, connectors and pins.
- Measure the power supply/battery voltage at the input terminal strip while the pump is running.
- The H-3551T has several safety features which may suspend pumping in order to preserve a dead battery. Refer to Chapter 2

Bubble Test

When visiting a gauge station it is recommended to always take a bucket and a length of rubber tubing. With the rubber tubing you can disconnect the station's orifice line and direct the gas flow into a bucket of water. This fast and productive test allows you to check for proper bubbling, leaks and other problems. Realize however, if the H-3551T was bubbling into deep water, when you direct the gas flow to a shallow bucket the bubble rate will be abnormally high for 5-10 minutes until the H-3551T can adjust to the new water depth.

It is also recommended to have dish detergent, a small paintbrush or "snoop" in your toolbox for testing for air leaks. Again, at 60 bubbles/minute, even a tiny leak will allow the entire gas flow to escape to the atmosphere.



06 / SDI-12 COMMAND & RESPONSE PROTOCOL

SDI-12 Command & Response Protocol

This is a brief description of the Serial Digital Interface (SDI-12) Command and Response Protocol used by the WATERLOG® Series Model H-3551T bubbler. Included is a description of the commands and data format supported by the H-3551T.

Refer to the document "A SERIAL DIGITAL INTERFACE STANDARD FOR HYDROLOGIC AND ENVIRONMENTAL SENSORS." Version 1.2 April 12, 1996 Coordinated by the SDI-12 Support Group, 135 East Center, Logan, Utah.

During normal communication, the data recorder sends an address together with a command to the H-4161 SDI-12 interface. The H-4161 then replies with a "response." In the following descriptions, SDI-12 commands and responses are enclosed in quotes. The SDI-12 address and the command/response terminators are defined as follows:

"a" Is the sensor address. The following ASCII Characters are valid addresses: "0-9", "A-Z", "a-z", "*", "?". Sensors will be initially programmed at the factory with the address of "0" for use in single sensor systems. Addresses "1 to 9" and "A to Z" or "a to z" can be used for additional sensors connected to the same SDI-12 bus. Address "*" and "?" are "wild card" addresses which select any sensor, regardless of its actual address.

!" Is the last character of a command block.

"<cr><lf>" Are carriage return (0D) hex and line feed (0A) hex characters. They are the last two characters of a response block.

Notes:

- All commands/responses are upper-case printable ASCII characters.
- Commands must be terminated with a "!" character.
- Responses are terminated with <cr><lf> characters.
- The command string must be transmitted in a contiguous block with no gaps of more than 1.66 milliseconds between characters.

Command Summary

The H-3551TTT supports the following SDI-12 commands:

Standard Commands:

- aM!** Initiate purge
- aM1!** Initiate measurement
- aM2!** Initiate special measurement
- aD0!** Send data
- aV!** Verify
- al!** Send identification
- a!** Send acknowledge
- aAn!** Change address

SDI-12 COMMAND & RESPONSE

Extended Commands:

aXRBR!	Read bubble rate
aXWBRnn!	Write bubble rate
aXRPP!	Read purge pressure
aXWPPnn!	Write purge pressure
aXRPT!	Read purge time
aXWPTnn!	Write purge time
aXTPM!	Test pump motor
aXTPV!	Test purge valve
aXTAZ!	Test auto-zero valve
aXCOP!	Test the COP timer
aXTEST!	Display the current settings
aXHELP!	Display the supported commands

Measure Command

The H-3351T supports three measure commands. Data values generated in response to these commands are stored in the sensor's buffer for subsequent collection using "D" commands. The data will be retained in the sensor until another "M", "C", or "V" command is executed.

<u>Command</u>	<u>Response</u>	<u>Description</u>
"aM!"	"atttn<cr><lf>"	Initiate measurement

Where:

- a is the sensor address ("0-9", "A-Z", "a-z", "*", "?").
- M is an upper-case ASCII character
- ttt is a three digit integer (000-999) specifying the maximum time, in seconds, the sensor will take to complete the command and have measurement data available in its buffer.
- n is a single digit integer (0-9) specifying the number of values that will be placed in the data buffer. If "n" is zero (0), no data will be available using subsequent "D" commands

Upon completion of the measurement, a service request "a<cr><lf>" may be sent to the data recorder indicating the sensor data is ready. The data recorder may wake the sensor with a break and collect the data any time after the service request is received or the specified processing time has elapsed.

The aM! causes the H-3551T to initiate a purge sequence. Upon completion of the purge the H-3551T places a success/fail response parameter in the sensor buffer and sends a service request

Example of a H-3551T "aM!" command:

<u>Command</u>	<u>Response</u>	<u>Time</u>	<u>Values</u>	<u>Description</u>
"aM!"	"a2721<cr><lf>"	272 sec	1	Initiate a purge
<u>Subsequent Command</u>	<u>Response</u>	<u>Description</u>		
"aD0"	a+0<cr><lf>	Purge failed (low battery voltage)		
"aD0"	a+1<cr><lf>	Purge succeeded		

The aM1! causes the H-3351 to initiate a measurement . This command takes less than 3 seconds to complete and places 5 parameters in the sensor buffer.

Example of a H-3551TT "aM1!" command:

<u>Command</u>	<u>Response</u>	<u>Time</u>	<u>Values</u>	<u>Description</u>
"aM1!"	"a0035<cr><lf>"	3 sec	5	Initiate a measurement
<u>Subsequent Command</u>	<u>Response</u>	<u>Description</u>		
"aD0"	a+AA.AAA+BB.BBB+CC.CCC+DD.DD+EE.EE<cr><lf>			
where: AA.AAA	= Tank pressure (PSI)			
BB.BBB	= Line pressure (PSI)			
CC.CCC	= Sensor temperature (°C)			
DD.DD	= System battery voltage (volts)			
EE.EE	= Pump battery voltage (volts)			

The aM2! causes the H-3351 to initiate a measurement . This command takes less than 3 seconds to complete and places 8 parameters in the sensor buffer. This command is normally used only for calibration and test during manufacturing.

Example of a H-3551T "aM2!" command:

<u>Command</u>	<u>Response</u>	<u>Time</u>	<u>Values</u>	<u>Description</u>
"aM2!"	"a0038<cr><lf>"	3 sec	8	Initiate a measurement
<u>Subsequent Command</u>	<u>Response</u>	<u>Description</u>		
"aD0"	a+AA.AA+BB.BB+CCCC+DDDD+EE.EE+FF.FF+GGGG+HHHH<cr><lf>			
where: AA.AA	= Tank pressure (PSI)			
BB.BB	= Tank temperature (°C)			
CCCC	= Tank pressure (raw A/D counts)			
DDDD	= Tank temperature (raw A/D counts)			
EE.EE	= Line pressure (PSI)			
FF.FF	= Line temperature (°C)			
GGGG	= Line pressure (raw A/D counts)			
HHHH	= Line temperature (raw A/D counts)			

SDI-12 COMMAND & RESPONSE

Concurrent Measure Command

This is a new command for the Version 1.2 SDI-12 Specification. A concurrent measurement is one which occurs while other SDI-12 sensors on the bus are also taking measurements. This command is similar to the "aM!" command, however, the nn field has an extra digit and the sensor does not issue a service request when it has completed the measurement. Communicating with other sensors will NOT abort a concurrent measurement. Data values generated in response to this command are stored in the sensor's buffer for subsequent collection using "D" commands. The data will be retained in the sensor until another "M", "C", or "V" command is executed.

<u>Command</u>	<u>Response</u>	<u>Description</u>
"aC!"	"atttnn<cr><lf>"	Initiate measurement

Where:

- a is the sensor address ("0-9", "A-Z", "a-z", "*", "?").
- C is an upper-case ASCII character
- ttt is a three digit integer (000-999) specifying the maximum time, in seconds, the sensor will take to complete the command and have measurement data available in its buffer.
- nn is a two digit integer (00-99) specifying the number of values that will be placed in the data buffer. If "n" is zero (0), no data will be available using subsequent "D" commands.

The data recorder may wake the sensor with a break and collect the data anytime after the specified processing time has elapsed.

Send Data Command

The Send Data command returns sensor data generated as the result of previous "aM!", "aM1!", "aM2!", "aC!", "aC1!", "aC2!" or "aV!" commands. Values returned will be sent in 33 characters or less. The sensor's data buffer will not be altered by this command.

<u>Command</u>	<u>Response</u>
"aD0!"	"apd.d<cr><lf>"

Where:

- a is the sensor address ("0-9", "A-Z", "a-z", "*", "?").
- D0 are upper-case ASCII characters.
- p is a polarity sign (+ or -)
- d.d represents numeric digits before and/or after the decimal. A decimal may be used in any position in the value after the polarity sign. If a decimal is not used, it will be assumed to be after the last digit.

For example: +3.29 +23.5 -25.45 +300

If the "aD0!" returns no data ("a<cr><lf>" only), it means that no measurement data is available (or the measurement was aborted) and a new "M" command must be sent.

Example of a H-3551T "aD0!" command:

<u>Previous Command</u>	<u>Response</u>	
"aM!"	"a2721<cr><lf>"	
<u>Subsequent Command</u>	<u>Response</u>	<u>Description</u>
"aD0"	a+0<cr><lf>	Purge failed (low battery)
"aD0"	a+1<cr><lf>	Purge succeeded

Send Acknowledgement Command

The Send Acknowledge Command returns a simple status response which includes the address of the sensor. Any measurement data in the sensor's buffer is not disturbed.

<u>Command</u>	<u>Response</u>
"a!"	"a<cr><lf>"

Where: a is the sensor address ("0-9", "A-Z", "a-z", "*", "?")

Initiate Verify Command

The Verify Command causes a verify sequence to be performed. The result of this command is similar to the "aM!" command except that the values generated are fixed test data and the results of diagnostic checksum tests. The data generated in response to this command is placed in the sensor's buffer for subsequent collection using "D" commands. The data will be retained in the sensor until another "M", "C", or "V" command is executed.

<u>Command</u>	<u>Response</u>	<u>Description</u>
"aV!"	"atttn<cr><lf>"	Initiate verify sequence

Where: a is the sensor address ("0-9", "A-Z", "a-z", "*", "?").
 V is an upper-case ASCII character.
 ttt is a three digit integer (000-999) specifying the maximum time, in seconds, the sensor will take to complete the command and have data available in its buffer.
 n is a single digit integer (0-9) specifying the number of values that will be placed in the data buffer. If "n" is zero (0), no data will be available using subsequent "D" commands

SDI-12 COMMAND & RESPONSE

Example of a "aV!" command:

<u>Command</u>	<u>Response</u>	<u>Time</u>	<u>Values</u>	<u>Description</u>
"aV!"	"a0014<cr><lf>"	1 sec	4	Return fixed data and diagnostic data for testing purposes.
<u>Subsequent Command</u>		<u>Response</u>		
"aD0"		a+123.456+78.9+x+y<cr><lf>		
<u>Key</u>	<u>Description</u>	<u>Units</u>		
+123.456	Fixed test data			
+78.9	Fixed test data			
x	Memory checksum	0-65535		
y	Checksum test	"0" = Failed, "1" = Passed		

Send Identification Command

The Send Identification Command responds with sensor vendor, model, and version data. Any measurement data in the sensor's buffer is not disturbed.

<u>Command</u>	<u>Response</u>
"a!"	"allccccccmmmmmmvvvxx...xx<cr><lf>"

Where:a	is the sensor address ("0-9", "A-Z", "a-z", "*", "?").
l	is an upper-case ASCII character.
ll	is the SDI-12 version compatibility level, e.g. version 1.2 is represented as "12".
cccccc	is an 8 character vendor identification to be specified by the vendor and usually in the form of a company name or its abbreviation.
mmmmmm	is a 6 character field specifying the sensor model number.
vvv	is a 3 character field specifying the sensor version number.
xx...xx	is an optional field of up to a maximum of 13 characters to be used for serial number or other specific sensor information not relevant to operation of the data recorder

Example of a "a!" command:

<u>Command</u>
"a12 DAA H-3551TvvS#nnnnnnVkkk<cr><lf>"

H-3551T implementation of the optional 13 character field: S#nnnnnnVkkk (12 bytes total)

Where:"nnnnnn	is a six character sensor serial number
"kkk"	is a three digit sensor firmware revision level

Change Sensor Address Command

The Change Sensor Address Command allows the sensor address to be changed. The address is stored in non-volatile Flash memory within the sensor. The H-3551T will not respond if the command was invalid, the address was out of range, or the Flash programming operation failed

<u>Command</u>	<u>Response</u>	<u>Description</u>
"aAn!	"n<cr><lf>"	Change sensor address

Where: a is the current (old) sensor address ("0-9", "A-Z", "a-z", "*", "?"). An ASCII "*" may be used as a "wild card" address if the current address is unknown and only one sensor is connected to the bus.

A is an upper-case ASCII character.

n is the new sensor address to be programmed ("0-9", "A-Z").

NOTE: To verify the new address use the "IdentifyCommand".

Example of a "Change Sensor Address" command:

<u>Command</u>	<u>Response</u>	<u>Description</u>
"aA2!"	"2<cr><lf>"	Change sensor address to "2"

Extended Read/Write BubbleRate, PurgePressure and PurgeTime

These commands allow the user to read or write several bubbler configuration settings. The settings are stored in non-volatile Flash memory. Once the new value is written to the Flash memory, a copy is sent to the sensor data buffer for verification. This data can be viewed by using a subsequent "D" command. To verify these settings any other time, use the respective read commands. These commands take 1 second to complete and place 1 value in the data buffer. The H-3551T will only accept settings within a specific range as listed below.

<u>Command</u>	<u>Response</u>	<u>Description</u>
"aXRBR!"	"a0011<cr><lf>"	Read bubble rate setting (bub/min)
"aXRPP!"	"a0011<cr><lf>"	Read purge pressure setting (psi)
"aXRPT!"	"a0011<cr><lf>"	Read purge time setting (seconds)
"aXWBRdd!"	"a0011<cr><lf>"	Write bubble rate setting(bub/min)
"aXWPPdd!"	"a0011<cr><lf>"	Write purge pressure setting (psi)
"aXWPTdd!"	"a0011<cr><lf>"	Write purge time setting (seconds)

Where: a is the sensor address ("0-9", "A-Z", "a-z", "*", "?").

XRBR are upper case characters.

XRPP are upper case characters.

XRPT are upper case characters.

XWBR are upper case characters.

XWPP are upper case characters.

XWPT are upper case characters.

ddd is the new value (For example: 20.0, 195)

SDI-12 COMMAND & RESPONSE

Table 6-1: Max/min Settings

Parameter	Min	Max	Units
Bubble Rate	30	120	bubbles/min
Purge Pressure	15	80	psi
Purge Time	30	240	seconds

Example of a H-3551T Extended Read Bubble Rate command:

Command	Response	Time	Values	Description
"aXRBR!"	"a0011<cr><lf>"	1 sec	1	Read <i>BubbleRate</i>
Command	Response	Description		
"aD0!"	"a+50.0<cr><lf>"	<i>BubbleRate</i> is 50 bubbles/min		

Example of a H-3551T Extended Write Bubble Rate command:

Command	Response	Time	Values	Description
"aXWBR30.0!"	"a0011<cr><lf>"	1 sec	1	Write <i>BubbleRate</i>
Command	Response	Description		
"aD0!"	"a+30.0<cr><lf>"	<i>BubbleRate</i> is 30.0 bubbles/min		

Extended Test Pump Motor Command

This command is used during installation and testing to activate the pump motor for 5.0 seconds.

Example of a H-3551T Extended "Test Pump Motor" command:

Command	Response	Description
"aXTPM!"	"0050<cr><lf>"	Activate the pump motor for 5 seconds

Extended Test Purge Valve Command

This command is used during installation and testing to activate the purge valve solenoid for 5.0 seconds.

Example of a H-3551T Extended "Test Purge Valve" command:

Command	Response	Description
"aXTPV!"	"0050<cr><lf>"	Activate the purge valve for 5 seconds

Extended Test Auto-Zero Valve Command

This command is used during installation and testing to activate the auto-zero valve solenoid for 5.0 seconds.

Example of a H-3551T Extended "Test Auto-Zero Valve" command:

<u>Command</u>	<u>Response</u>	<u>Description</u>
"aXTAZ!"	"0050<cr><lf>"	Activate the auto-zero valve for 5 seconds

Extended Test COP (Computer Operating Properly) Timer Command

This command causes the COP timer to expire which in turn should initiate a system reset.

Example of a H-3551T Extended "Test COP Timer" command:

<u>Command</u>	<u>Response</u>	<u>Description</u>
"aXCOPT!"	"0050<cr><lf>"	Test the COP timer

Extended "XTEST" Command

This command is used for installation and testing and requires the use of a H-4191 Sidekick interface and a PC. This command causes the H-3551T to display a listing of the H-3551T's current settings, followed by a repeating printout of real-time measurement data. This is not compliant with the SDI-12 specification and is not used with data loggers.

An example of an "XTEST" printout is shown below:

H-3551 Settings:

- Firmware Checksum = PASS
- Bubbler Mode = Remote Host
- Bubble Rate (bub/s) = 60
- Hysteresis (psi) = 0.50
- Purge Pressure (psi) = 40.00
- Purge Threshold (psi)= 20.00
- Purge Time (sec) = 45
- AZ Interval (min) = 30

Tank_PSI=xx.xxx, Tank_TEMP=xx.xx, Tank_Vp=xxxxx, Tank_Vt=xxxxx
 Line_PSI=xx.xxx, Line_TEMP=xx.xx, Line_Vp=xxxxx, Line_Vt=xxxxx

Tank_PSI=xx.xxx, Tank_TEMP=xx.xx, Tank_Vp=xxxxx, Tank_Vt=xxxxx
 Line_PSI=xx.xxx, Line_TEMP=xx.xx, Line_Vp=xxxxx, Line_Vt=xxxxx

Tank_PSI=xx.xxx, Tank_TEMP=xx.xx, Tank_Vp=xxxxx, Tank_Vt=xxxxx
 Line_PSI=xx.xxx, Line_TEMP=xx.xx, Line_Vp=xxxxx, Line_Vt=xxxxx

etc.

SDI-12 COMMAND & RESPONSE

Extended "XHELP" Command

This command is used for installation and testing and requires the use of a H-4191 Sidekick interface and a PC. This command causes the H-3551T to display a listing of the supported SDI-12 commands. This is not compliant with the SDI-12 specification and is not used with data loggers.

An example of the "XHELP" printout is shown below:

H-3551 SDI-12 Commands:

M Initiate Purge (aM!)

M1 Make measurement (aM1!)

(TankPSI:LinePSI:Temperature:SysBat:PumpBat)

M2 Make measurement (aM2!)

(TankPSI:TankTemp:TankVp:TankVt:LinePSI:LineTemp:LineVp:LineVt)

D Send Data (aD0!)

V Verify (aV!)

I Send Identification (aI!)

! Send Acknowledge (a!)

An Change Address (aAn!)

Extended Commands:

XRBR Read bubble rate

XWBRnn Write bubble rate

XRPP Read purge pressure

XWPPnn Write purge pressure

XRPT Read purge time

XWPTnn Write purge time

XTPM Test pump motor

XTPV Test purge valve

XTZV Test auto-zero valve

XCOPT Test COP timer

XTEST Make repeating measurements

XHELP Print this listing



07 / APPENDIX

APPENDIX

Appendix A: Specifications

ENVIRONMENTAL	
Standard Operating Range	-40° to 60° C
Storage	-50° to 80° C
It is recommended the H-3551T be installed in a weather shielded enclosure (gauge station)	
GAS DELIVERY	
Control System	Microprocessor controlled
Technology	Constant mass flow
Gas Flow Control	Bubble rate is user selectable from 30 to 120 bubbles per minute. Built-in auto zero compensation. No needle valve (patent application in process)
COMPRESSOR	
Type	HI-REL medical grade ISO 9003 qualified piston compressor (avoids broken diaphragm problems) Serviced for extended temperature operation
Operation	Low duty cycle 5 hours typical runtime per year at 60 bubbles per minute
Pumping Time	1-second (average)
PURGE FUNCTIONS	
Purge Pressure	User selectable 15 PSI to 80 PSI
Options	<ol style="list-style-type: none"> 1. Manual 2. Internally sensed 3. Automatic timed interval 4. Remote controlled
CONTROL INTERFACE	
Type	RS-485
Protocol	ASCII
Baud Rate	9600 bps, half-duplex, 8 bit, no parity, 1 stop bit
POWER	
Qualified for operation with a 12-volt battery	
Supply Inputs	<ol style="list-style-type: none"> 1. Electronics supply via the RS-485 cable 2. Compressor supply
Voltage	10 to 16 volts
Current	15 milliamperes average (@ 60 bub/min)
Max Current	3.0A (pump running)

PHYSICAL	
Enclosure	Corrosion resistant, Type 4X molded fiberglass, hinged cover, seamless foam-in-place gasket
Size	10.5 in. W x 12.5 in. L x 6.0 in. D
Weight	12 lbs
Mounting	Hardware supplied for wall mounting
Pressure Outlet	1/8 in. FNPT
Sensor Pressure Outlet	1.8 in. FNPT
Air Intake	1/8 in. FNPT
Pressure relief valve	Internal
MISCELLANEOUS	
Ordering Information	H-3551 Base model H-3551/000 Standard H-355 "smart gas" system H-3551/350 Combination H-3551 "smart gas" system and H-350 pressure measurement system
Warranty	The WaterLOG® H-3611/H-3612/H-3613 series radars are warranted against defects in materials and workmanship for two years from date of shipment.
Notes	Specifications subject to change without prior notice due to ongoing commitment to product testing and improvement. LR June 17, 2013 (D4 0613)

Appendix B: Dry Air System

Figure B-1 shows the connections for a typical H-3551T dry air system.

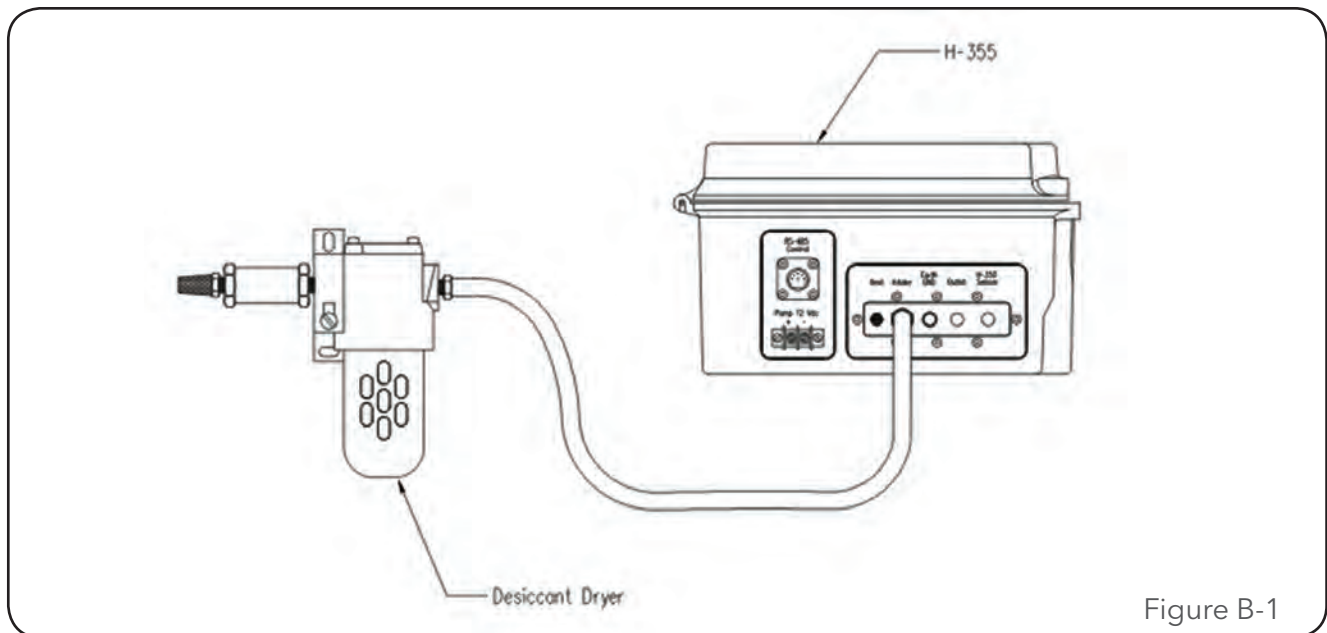

Figure B-1

The following on page 32 is the installation and maintenance documentation for a recommended desiccant dryer.

APPENDIX

WILKERSON®

Richland, MI 49083

Tel: (269) 629-5000

WARNING

To avoid unpredictable system behavior that can cause personal injury and property damage:

- Disconnect electrical supply (when necessary) before installation, servicing, or conversion.
- Disconnect air supply and depressurize all air lines connected to this product before installation, servicing, or conversion.
- Operate within the manufacturer's specified pressure, temperature, and other conditions listed in these instructions.
- Medium must be moisture-free if ambient temperature is below freezing.
- Service according to procedures listed in these instructions.
- Installation, service, and conversion of these products must be performed by knowledgeable personnel who understand how pneumatic products are to be applied.
- After installation, servicing, or conversion, air and electrical supplies (when necessary) should be connected and the product tested for proper function and leakage. If audible leakage is present, or the product does not operate properly, do not put into use.
- Warnings and specifications on the product should not be covered by paint, etc. If masking is not possible, contact your local representative for replacement labels.

Safety Guide

For more complete information on recommended application guidelines, see the Safety Guide section of Pneumatic Division catalogs or you can download the Pneumatic Division Safety Guide at: www.wilkinsoncorp.com

Description

Wilkinson Manual Dryers are intended to remove water vapor from the compressed air system. Atmospheric dew points as low as -100°F (-73°C) are achievable when operated within rated unit specifications.

General Safety Information

- Release all air pressure from intended airline before installation.
- Install unit in air line before opening desiccant container. After unit installation, add desiccant following steps in desiccant replacement instructions on page 2.
- Always make sure bowl, bowl guard, and clamp ring are in place and the clamp ring is securely locked before pressurization.
- DO NOT exceed the pressure and temperature ratings as shown in the specifications.
- Follow all local, state and federal EPA, OSHA, and similar codes regarding disposal of old desiccant.



Specifications	X06	X03 Plastic Bowl	X03 Metal Bowl	X04	X25 Metal Bowl
Maximum Pressure	150 psig (10.3 bar)	150 psig (10.3 bar)	150 psig (10.3 bar)	150 psig (10.3 bar)	150 psig (10.3 bar)
Maximum Temperature	125°F (52°C)	125°F (52°C)	150°F (66°C)	125°F (52°C)	150°F (66°C)
Atmospheric Dewpoint*	000 Model: -45°F (-43°C) U00 Model: 4A Molecular Sieve -100°F (-73°C)	000 Model: -45°F (-43°C) U00 Model: -100°F (-73°C)	M00 Model: -45°F (-43°C) MU0 Model: -100°F (-73°C)	000 Model: -45°F (-43°C) U00 Model: -100°F (-73°C)	000 Model: -45°F (-43°C) U00 Model: -100°F (-73°C)
Maximum Continuous Airflow*	5 scfm (2.3 dm³/s)	10 scfm (4.7 dm³/s)	10 scfm (4.7 dm³/s)	10 scfm (4.7 dm³/s)	25 scfm (11.8 dm³/s)
Total Airflow*	600 scf (283 dm³)	4400 scf (2076 dm³)	4400 scf (2076 dm³)	4400x2 scf (2076x2 dm³)	11,000 scf (5194 dm³)
Total Min. of Operation @ Max. Continuous Airflow	120 min.	440 min.	440 min.	880 min.	440 min.
Unit Weight With Desiccant	1.13 lbs. (0.51 kg)	7.4 lbs. (3.4 kg)	6.8 lbs. (3.1 kg)	15.0 lbs. (6.8 kg)	11.2 lbs. (5.1 kg)
# of Desiccant Bags/Charge	1 Bag**	2 Bags***	2 Bags***	4 Bags***	5 Bags***
Pipe Connections	1/4" NPT (BSPP)	1/4", 1/2" NPT (BSPP)	1/4", 1/2" NPT (BSPP)	1/4", 1/2" NPT (BSPP)	1/2" NPT (BSPP)

*With Dry Desiccant at 100 psig (7 bar) and 70°F (21°C)

** Each bag weighs: 25 lbs. (.11kg)

*** Each bag weighs: 88 lbs. (.40kg)

Installation & Service Instructions 83-050-000

Manual Desiccant Dryer Models
X06, X03, X04, and X25 with
Variations and Accessories

ISSUED: April, 2007

Supersedes: October, 2004

Doc. #83050000, EN #070216, Rev. 3

Installation

1. Refer to WARNING (on page 6).
2. Install as close as possible to the point where the air is being used.
3. Install unit with the airflow going in the direction of the arrow. For the X04, install with airflow entering at the bottom center port of the 4-way valve and exiting at the center port of the shuttle valve.
4. Install unit on air line before opening desiccant container. After installation, add desiccant. Shake and tap bowl while filling to settle desiccant. Fill Model X25 and X03/X04 to 1/8" below inner shoulder of bowl. Fill Model X06 bowl to within 1/2" of top.
5. Replace bowl and bowl guard, or metal bowl, and clamp ring onto the unit. Be sure clamp ring is securely locked in place before pressurizing unit.
6. Most manual desiccant dryer users will achieve optimal results when installing the dryer as close to the equipment or process being protected as possible in the compressed air system. Most users, especially those with high quality air requirements, should protect their system and the manual dryer with one or more of the following types of components: Please see page 4 for exact model recommendations.

- **Liquid Separator:** Should be used prior to the manual desiccant dryer in any system where large slugs of liquid water are anticipated. The manual desiccant dryer silica gel or mole sieve can be destroyed by large amounts of liquid moisture. Most systems which have an aftercooler and separator, and/or a refrigerated air dryer, will not require a liquid separator. An alternative is to use a particulate filter/separator, described below.

- **Particulate Filter/Separator:** Should be used prior to the manual desiccant dryer in any system where significant amounts of dirt, pipe scale, etc. and/or liquid water, is present, in order to prevent clogging the manual dryer or harming the desiccant. A particulate filter/separator should be used prior to a coalescing filter to extend the life of the coalescing element.

Appendix

Models X06, X03, X04, and X25

- **Coalescing Filter:** Should be used prior to the manual desiccant dryer in any lubricated compressor system which does not utilize a system coalescing filter. The coalescing filter removes oil from the compressed air, which prevents the oil from coating the silica gel or mole sieve and destroying its ability to dry the air. Oil contaminated desiccant must be replaced and disposed of properly, as it cannot be regenerated.
- **Afterfilter:** Should be used after the manual desiccant dryer in any system where any amount of desiccant dust, however insignificant, is undesirable. The afterfilter prevents the very slight desiccant dusting, which occurs over time, from proceeding downstream into the compressed air system.
- **Pre-Dryers:** Both the silica gel and mole sieve manual desiccant dryers can have their drying lives extended through the use of a pre-dryer. The silica gel ("000"/"M00") models will typically last over three times as long if a refrigerated air dryer is placed in the compressed air system prior to it. (A plant air system refrigerated dryer will provide the same extended life.) The mole sieve ("U00"/"MU0") models will typically last three times as long if a silica gel ("000"/"M00") model dryer installed prior to the mole sieve dryer. (A plant air system desiccant dryer will provide the same extended life.) Users of either type of manual desiccant dryer who expect a high air flow demand may wish to consider using a pre-dryer. Please see page 4 for exact model recommendations.

Operation

1. The silica gel desiccant, when visible through the clear polycarbonate plastic bowl, contains a color indicator. It changes from Blue (meaning dry) to Pink (meaning wet) to indicate the need to replace or regenerate the desiccant. (An X05-02-000 moisture indicator can be used with 4A molecular sieve units to perform the same function.) On units with metal bowls, a moisture indicator mounted on the cover performs the same color changing function.
2. The 4A molecular sieve does not change color. For moisture indication an X05-02-000 is recommended. See page 4.
3. Environment friendly desiccant changes color from yellow (meaning dry) to green (meaning wet).
3. By installing two or more units in parallel, higher dry airflows can be achieved.

Maintenance

1. The only servicing required for silica gel units is when the desiccant color or moisture indicator has changed from Blue (meaning dry) to Pink (meaning wet). Should this color change occur:
 - a. Turn off and depressurize the line containing the dryer unit.
 - b. Loosen the clamp ring and remove the bowl from the top housing. (Figure 1) Proceed to step 2 or 3, as required.
2. **Desiccant replacement:**
 - a. Pour out used desiccant.
 - b. Open new container and refill bowl. (Figure 2)
 - c. Shake or tap bowl to settle desiccant. Add or remove sufficient quantity to fill Model X03 and X25 unit bowl to 1/8" below inner step, and for Model X06 fill bowl to within 1/2" of the top. (Figure 3)

- d. See replacement parts list for specifics on kit numbers for replacement desiccant.
3. **Desiccant regeneration:**
 - a. — For silica gel ("000") units: Pour out used Pink desiccant onto flat pan. Place Pink desiccant in 350°F (176°C) oven for approximately three hours or until the desiccant color has changed back to Blue.
 - For 13x molecular sieve ("X00") units cannot be regenerated. See page 5 for replacement kits.
 - For 4A molecular sieve ("U00") units: Pour out used desiccant onto flat pan. Place desiccant in 600°F (316°C) oven for up to a maximum of 3 hours.
 - b. Remove desiccant from oven and allow to cool down to ambient temperature.
 - c. Pour desiccant back into unit bowl, periodically shaking and tapping to settle the desiccant.
4. Replace bowl and bowl guard, or metal bowl, and clamp ring onto the unit. Be sure clamp ring is securely locked in place before repressurizing the unit.

CAUTION

Polycarbonate bowls, being transparent and tough, are ideal for use with Filters and Lubricators. They are suitable for use in normal industrial environments, but should not be located in areas where they could be subjected to direct sunlight, an impact blow, nor temperatures outside of the rated range. As with most plastics, some chemicals can cause damage. Polycarbonate bowls should not be exposed to chlorinated hydrocarbons, ketones, esters and certain alcohols. They should not be used in air systems where compressors are lubricated with fire-resistant fluids such as phosphate ester and di-ester types.

Metal bowls are recommended where ambient and/or media conditions are not compatible with polycarbonate bowls. Metal bowls resist the action of most such solvents, but should not be used where strong acids or bases are present or in salt laden atmospheres. Consult the factory for specific recommendations where these conditions exist.

TO CLEAN POLYCARBONATE BOWLS USE MILD SOAP AND WATER ONLY! DO NOT use cleansing agents such as acetone, benzene, carbon tetrachloride, gasoline, toluene, etc., which are damaging to this plastic.

Bowl guards are recommended for added protection of polycarbonate bowls where chemical attack may occur.

WARNING

FAILURE OR IMPROPER SELECTION OR IMPROPER USE OF THE PRODUCTS AND/OR SYSTEMS DESCRIBED HEREIN OR RELATED ITEMS CAN CAUSE DEATH, PERSONAL INJURY AND PROPERTY DAMAGE.

This document and other information from The Company, its subsidiaries and authorized distributors provide product and/or system options for further investigation by users having technical expertise. It is important that you analyze all aspects of your application, including consequences of any failure and review the information concerning the product or systems in the current product catalog. Due to the variety of operating conditions and applications for these products or systems, the user, through its own analysis and testing, is solely responsible for making the final selection of the products and systems and assuring that all performance, safety and warning requirements of the application are met. The products described herein, including without limitation, product features, specifications, designs, availability and pricing, are subject to change by The Company and its subsidiaries at any time without notice.

EXTRA COPIES OF THESE INSTRUCTIONS ARE AVAILABLE FOR INCLUSION IN EQUIPMENT / MAINTENANCE MANUALS THAT UTILIZE THESE PRODUCTS. CONTACT YOUR LOCAL REPRESENTATIVE.

Figure 1

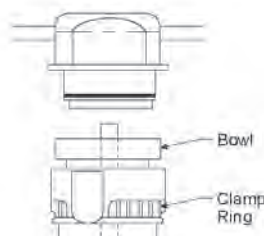

X03 / X04 / X25

Figure 2

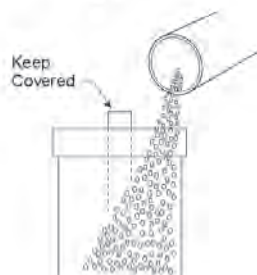
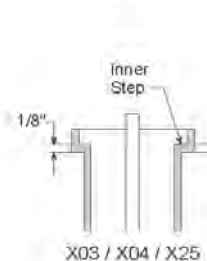
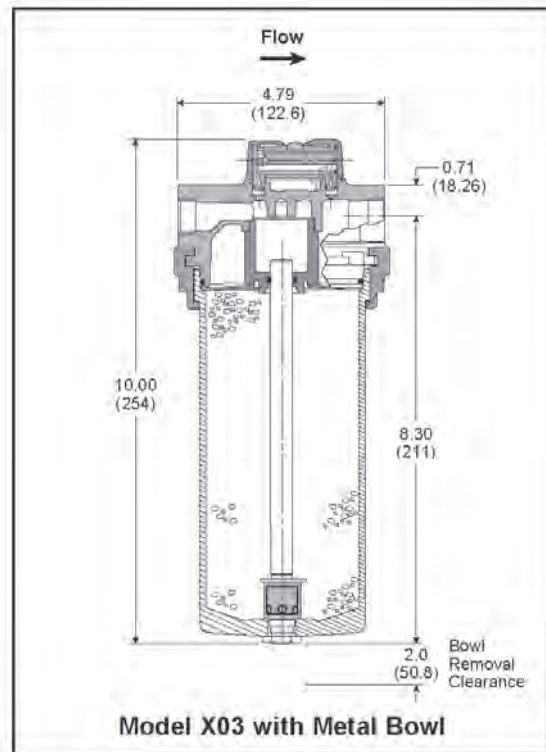
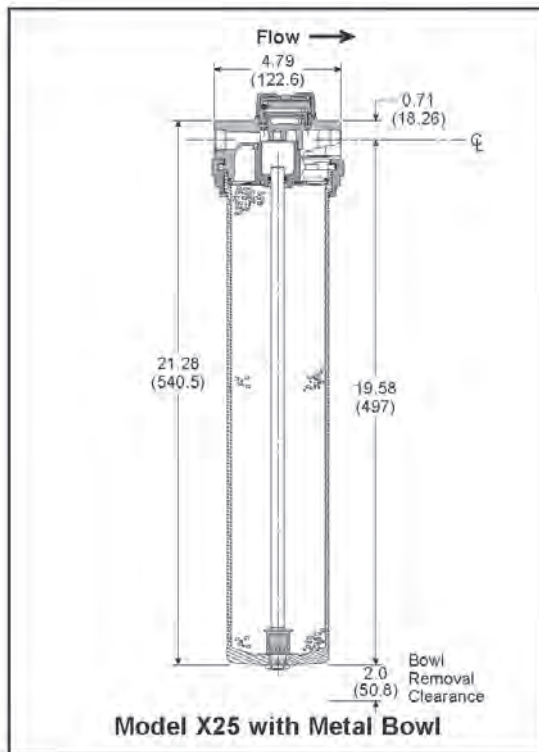
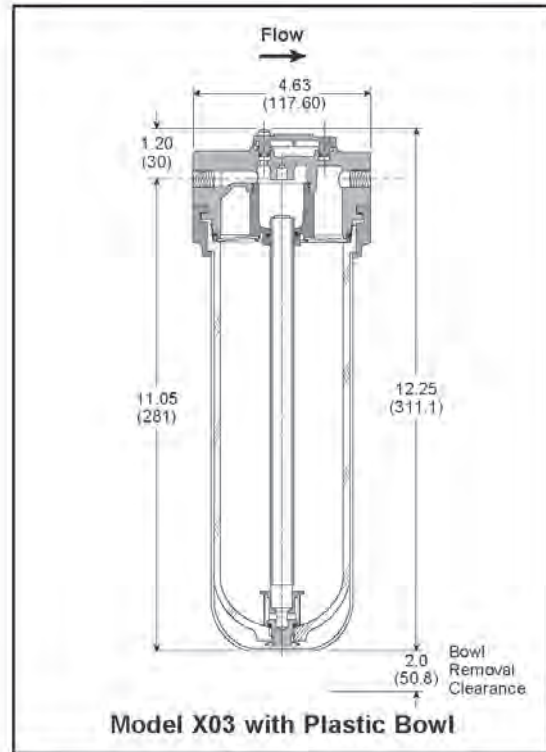
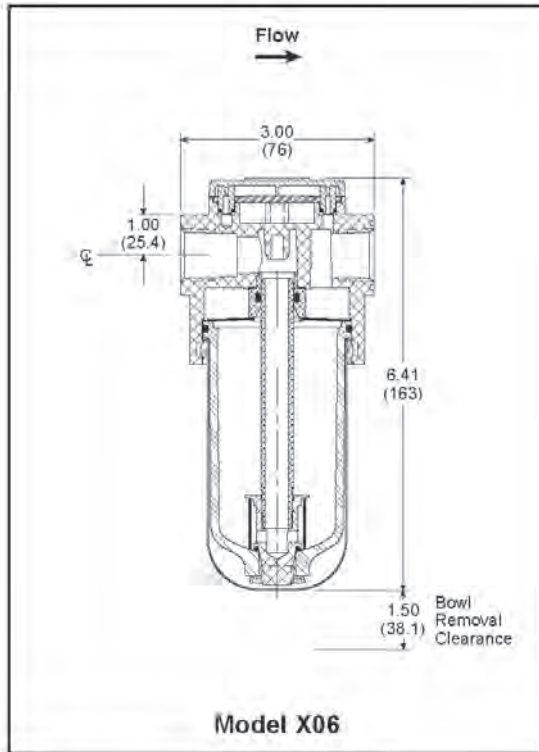

Figure 3



X03 / X04 / X25

APPENDIX



Appendix

Recommended Liquid Separators, Filters and Pre-Dryers

(use as necessary for specific system requirements)

Manual Desiccant Dryer Model Used	Liquid Separator	Particulate Filter/Separator (5 micron)	Coalescing Filter (0.5 micron)	Afterfilter (0.5 micron)	Pre-Drying Manual Desiccant or Refrigerated Air Dryer, For Extended Life	Total Desiccant Life if Pre-Drying Dryer Used
Silica Gel For -45°F (-42°C) Atmospheric Dewpoint:						
X06-02-000	WSA-02-FM0	F16-02-F00	M16-02-FS0	AF1-02-S00	WRA-0010	2200 SCF
X03-XX-000/M00	WSA-XX-FM0	F16-XX-F00/M00	M16-XX-FS0/MS0	AF1-XX-S00	WRA-0010	16,000 SCF
X04-02-000	WSA-02-FM0	F16-02-F00	M16-02-FS0	AF1-02-S00	WRA-0010	32,000 SCF (16,000x2)
X25-04-000	WSA-04-FM0	F26-04-FM0	M26-04-FMS	AF2-04-S00	WRA-0025	40,000 SCF
Type 4A Molecular Model Sieve For -100°F (-73°C) Atmospheric Dewpoint:						
X06-02-U00	WSA-02-FM0	F16-02-F00	M16-02-FS0	AF1-02-S00	X06-02-000	1800 SCF
X03-XX-U00/MU0	WSA-XX-FM0	F16-XX-F00/M00	M16-XX-FS0/MS0	AF1-XX-S00	X03-XX-000/M00	13,200 SCF
X04-02-U00	WSA-02-FM0	F16-02-F00	M16-02-FS0	AF1-02-S00	X04-02-000	26,400 SCF (13,200x2)
X25-04-U00	WSA-04-FM0	F26-04-FM0	M26-04-FMS	AF2-04-S00	X25-04-000	33,000 SCF

Typical Installation Arrangement For Manual Dryers

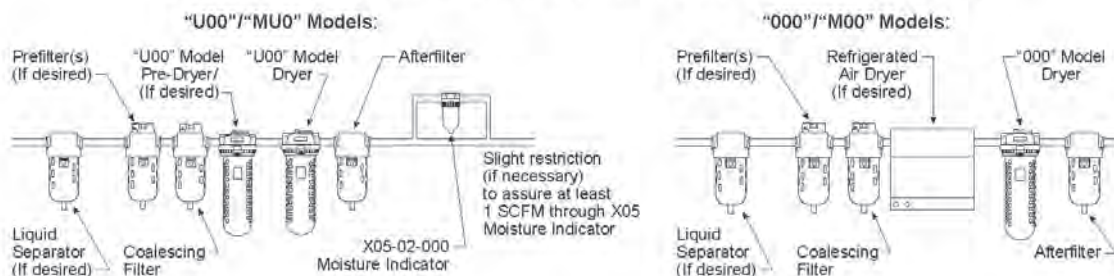

X04-02-000 Dryer

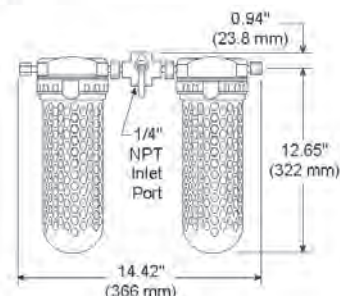
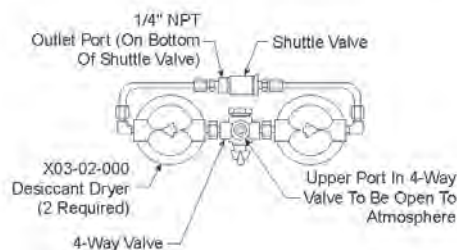

APPENDIX

Replacement Parts List — TRANSPARENT BOWL Units with Bowl Guards

Description	Part No. X06	Qty.	Part No.	X03 Qty.	X04 Qty.
1 Cover	NNR	—	NNR	—	—
2 Screen Assembly	NNR	—	NNR	1	2
3 Bowl O-Ring	GRP-95-259	1	GRP-95-256	1	2
4 Tube Assembly w/screen	N/A	1	DRP-96-435	1	2
5 Transparent Bowl	N/A	1	GRP-95-871	1	2
6 Silica Gel (000)	DRP-95-303	3 Bags / .75 lbs.	DRP-85-059	8 Bags / 7 lbs.	8 Bags / 7 lbs.
4A Molecular Sieve (U00)	DRP-95-304	3 Bags / .75 lbs.	DRP-85-060	8 Bags / 7 lbs.	8 Bags / 7 lbs.
13x Molecular Sieve (X00)	DRP-95-305	3 Bags / .75 lbs.	DRP-85-061	8 Bags / 7 lbs.	8 Bags / 7 lbs.
Environment Friendly (E00)	DRP-85-448	3 Bags / .75 lbs.	DRP-85-447	8 Bags / 7 lbs.	8 Bags / 7 lbs.
7 Bowl Guard	GRP-95-846	1	DRP-95-810	1	2
8 Clamp Ring	NNR	—	GRP-96-404	1	2

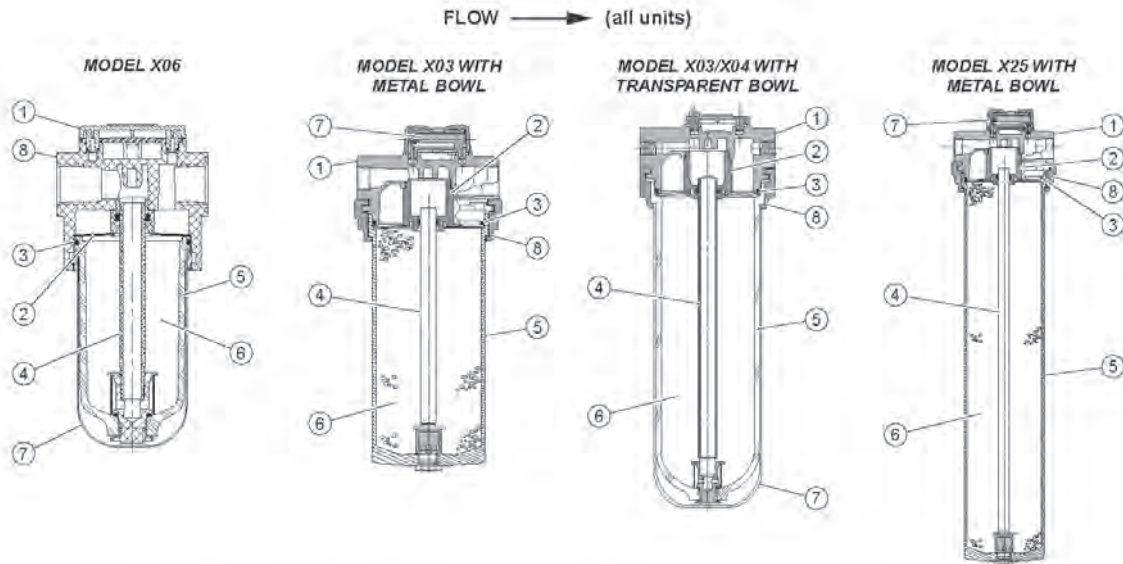

Replacement Parts List – METAL BOWL Units with Moisture Indicators

Description	Part No. X03	Qty.	Part No. X25	Qty.
1 Cover	NNR	—	NNR	—
2 Screen Assembly	GRP-96-434	1	GRP-96-434	1
3 Bowl O-Ring	GRP-95-256	1	GRP-95-256	1
4 Tube Assembly w/Screen	DRP-96-451	1	DRP-95-622	1
5 Metal Bowl	DRP-96-450	1	NNR	—
6 Silica Gel (000)	DRP-85-059	8 Bags / 7 lbs.	DRP-85-280	8 Bags / 7 lbs.
4A Molecular Sieve (U00)	DRP-85-060	8 Bags / 7 lbs.	DRP-95-624	8 Bags / 7 lbs.
13x Molecular Sieve (X00)	DRP-85-061	8 Bags / 7 lbs.	N/A	—
Environment Friendly (E00)	DRP-85-447	8 Bags / 7 lbs.	DRP-85-447	8 Bags / 7 lbs.
7 Moisture Indicator **	DRP-95-623	1	DRP-95-623	1
8 Clamp Ring	GRP-96-404	1	GRP-96-404	1

NNR: Not normally replaced

** The moisture indicator contains a weep orifice to provide an air sample to the moisture indicating paper. Air leakage from this indicator is necessary and normal.

Appendix

WILKERSON WARRANTY

Wilkerson products are warranted to be free from defects in material and workmanship, under proper use, installation, application and maintenance in accordance with Wilkerson's written recommendations and specification for a period of one year from the date of shipment from the factory (refrigerated dryers are warranted for 2 years). Wilkerson's obligation under this warranty is limited to, and the sole remedy for any such defect shall be, the repair or replacement (at Wilkerson's option) of unaltered products returned to Wilkerson and proven to have such defect, provided such defect is promptly reported to Wilkerson within said one-year period.

This is the only authorized Wilkerson Warranty and is in lieu of all other express or implied warranties or representations, including any implied warranties of merchantability or fitness, or of any other obligations on the part of Wilkerson.

Warranty claims must be submitted and shall be processed in accordance with Wilkerson's established warranty claim procedure. In no event will Wilkerson be liable for business interruptions, loss of profits, personal injury, costs of delay or for any other special, indirect, incidental or consequential losses, cost or damages.

WARNING: USE LIMITATIONS

Wilkerson's warranties are void, and Wilkerson assumes no responsibility for any resulting cost, loss, injury or any other damages whatsoever, with respect to any plastic bowl unit for which a bowl guard is standard equipment if the unit is placed in service without the bowl guard and, except as otherwise specified in writing by Wilkerson, with respect to any Wilkerson products which are used in other than compressed air service. Specific warnings with respect to these and other use limitations appear elsewhere in this catalog.

Wilkerson maintains a policy of ongoing product development and improvement. We therefore reserve the right to change dimensions specification and design without notice.

DO NOT PLACE PLASTIC BOWL UNIT IN SERVICE WITHOUT BOWL GUARD INSTALLED

Plastic bowl units are sold only with bowl guards with the exception to miniature units (C04, F00, L00, and M00). To minimize the danger of flying fragments in the event of plastic bowl failure, the bowl guards should not be removed. If the unit is in service without the bowl guard installed, manufacturer's warranties are void, and the manufacturer assumes no responsibility for any resulting loss.

If the unit has been in service and does not have a bowl guard, order one and install before placing back in service.

CAUTION

Certain compressor oils, chemicals, household cleaners, solvents, paints and fumes will attack plastic bowls and can cause bowl failure. Do not use near these materials. When bowl becomes dirty replace bowl or wipe only with a clean, dry cloth. Reinstall bowl guard or buy and install a bowl guard. Immediately replace any crazed, cracked, damaged or deteriorated plastic bowl with a bowl or a new plastic bowl and bowl guard.

CAUTION

Except as otherwise specified by the manufacturer, this product is specifically designed for compressed air service, and use with any other fluid (liquid or gas) is a misapplication. For example, use with or injection of certain hazardous liquids or gases in the system (such as alcohol or liquid petroleum gas) could be harmful to the unit or result in a combustible condition or hazardous external leakage. Before using with fluids other than air, or for non-industrial applications, or for life support systems, consult Wilkerson Corporation for written approval.

SOME OF THE MATERIALS THAT WILL ATTACK POLYCARBONATE PLASTIC BOWLS.

Acetaldehyde	Chlorobenzene	Methylene chloride
Acetic acid (conc.)	Chloroform	Methylene salicylate
Acetone	Cresol	Milk of lime (CaOH)
Acrylonitrile	Cyclohexanol	Nitric acid (conc.)
Ammonia	Cyclohexanone	Nitrobenzene
Ammonium fluoride	Cyclohexene	Nitrocellulose lacquer
Ammonium hydroxide	Dimethyl formamide	Phenol
Ammonium sulfide	Dioxane	Phosphorous hydroxy chloride
Anaerobic adhesives and sealants	Ethgane tetrachloride	Phosphorous trichloride
Antifreeze	Ethyl acetate	Propionic acid
Benzene	Ethyl ether	Pyridine
Benzoic acid	Ethylamine	Sodium hydroxide
Benzyl alcohol	Ethylene chlorohydrin	Sodium sulfide
Brake fluids	Ethylene dichloride	Styrene
Bromobenzene	Ethylene glycol	Sulfuric acid (conc.)
Butyric acid	Formic acid (conc.)	Sulphural chloride
Carbolic acid	Freon (refrig. & Propell.)	Tetrahydronaphthalene
Carbon disulfide	Gasoline (high aromatic)	Tiophene
Carbon tetrachloride	Hydrazine	Toluene
Caustic potash solution	Hydrochloric acid (conc.)	Turpentine
Caustic soda solution	Lacquer thinner	Xylene
	Methyl alcohol	Perchlorethylene & Others

TRADE NAMES OF SOME COMPRESSOR OILS, RUBBER COMPOUNDS AND OTHER MATERIALS THAT WILL ATTACK POLYCARBONATE PLASTIC BOWLS.

Atlas "Perma-Guard"	National Compound #N11
Buna N	"Nylock" VC-3
Cellulube #150 and #220	Parco #1306 Neoprene
Crylex #5 cement	*Permabond 910
*Eastman 910	Petron PD287
Garlock #98403 (polyurethane)	Prestone
Haskel #568-023	Pydraul AC
Hilgard Co.'s hil phene	Sears Regular Motor Oil
Houghton & Co. oil #1120, #1130 & #1055	Sinclair oil "Lily White"
Houtosafe 1000	Stauffer Chemical FYRQUEL #150
Kano Kroil	Stillman #SR 269-75 (polyurethane)
Keystone penetrating oil #2	Stillman #SR 513-70 (neoprene)
*Loctite 271	Tannergas
*Loctite 290	Telar
*Loctite 601	Tenneco anderol #495 & #500 oils
*Loctite Teflon-Sealant	Titon
Marvel Mystery Oil	*Vibra-tite
Minn. Rubber 366Y	Zerex

*When in raw liquid form.

We cannot possibly list all harmful substances, so check with Mobay or the General Electric office for further information on polycarbonate plastic.

The trade names "EconOmist" and "Flow-Guide" are registered at the United States Patent Office. "Auto-Fill", "Dial-Air", "Flex-Drain", "Mainliner" and "Whirl-Flo" are trade names of the Wilkerson Corporation.

WILKERSON PRODUCTS ARE PROTECTED BY THE FOLLOWING U.S. PATENT AND PATENTS IN OTHER COUNTRIES, ADDITIONAL PATENTS ARE PENDING.

3,631,878	3,667,493	3,762,224	4,215,790
4,215,790	3,793,803	4,718,245	3,793,803
3,858,403	D-292-310	D-229-629	4,215,790
4,289,335	4,352,611	4,559,065	4,631,073
4,689,969	4,696,320	3,889,484	3,945,465
4,631,073	D-234-848		

WILKERSON®

Customer/Technical Service
Pneumatic Division
Richland, MI 49083

Tel: (269) 629-2550
Fax: (269) 629-2475

Xylem

- 1) The tissue in plants that brings water upward from the roots;
- 2) a leading global water technology company.

We're 12,000 people unified in a common purpose: creating innovative solutions to meet our world's water needs. Developing new technologies that will improve the way water is used, conserved, and re-used in the future is central to our work. We move, treat, analyze, and return water to the environment, and we help people use water efficiently, in their homes, buildings, factories and farms. In more than 150 countries, we have strong, long-standing relationships with customers who know us for our powerful combination of leading product brands and applications expertise, backed by a legacy of innovation.

For more information on how Xylem can help you, go to www.xylem.com



Xylem–WaterLOG
1700/1725 Brannum Lane
Yellow Springs, Ohio
45387, USA
Tel +1.435.753.2212
Fax +1.435.753.7669
www.waterlog.com